

SPECIFICATION FOR APPROVAL

REF. :

PROD. NAME	SMD Power Inductor	ABC'S DWG NO.	SR1006□□□□L□-□□□		
		REV.	20150507-I	PAGE	1

I . Configuration and dimensions :

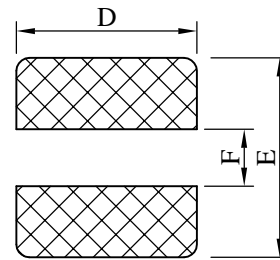
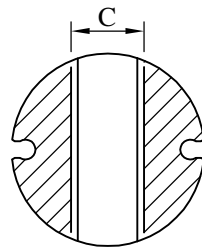
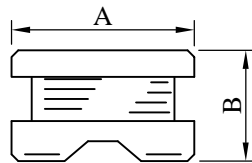
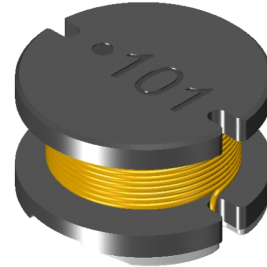
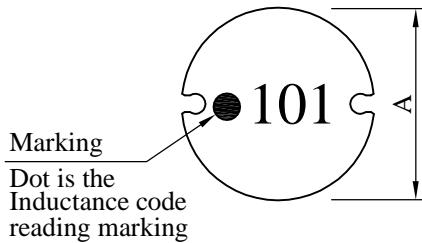

(PCB Pattern)

Unit : m/m

A	B	C	D	E	F
9.50 ±0.3	5.50 ±0.3	2.90 ref.	10.0 ref.	10.0 ref.	2.80 ref.

II . Description :

- a . Ferrite drum core construction.
- b . Enamelled copper wire : F 、 H class
- c . Product weight : 1.160g (ref.)
- d . Moisture sensitivity Level 1
- e . Products comply with RoHS' requirements
- f . Halogen free available

III . General specification :

- a . Storage temp. : -40°C ----+125°C
- b . Operating temp. : -40°C ----+125°C
(Temp. rise included)
- c . Resistance to solder heat : 245°C .10 secs.

Peak Temp : 245°C max.
Max. Peak Temp - 5°C : 30sec max.
Max time above 217°C : 60sec~150sec max.

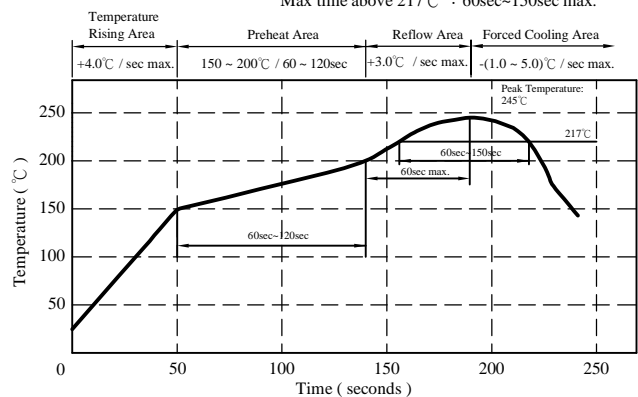

AR-001C

SPECIFICATION FOR APPROVAL

REF. :

PROD. NAME	SMD Power Inductor	ABC'S DWG NO.	SR1006□□□□L□-□□□		
		REV.	20150507-I	PAGE	2

IV . Electrical characteristics :

DWG No.	Inductance (μH)	Q ref.	Test Freq. (Hz)		SRF (MHz) nom.	RDC (Ω) max.	IDC (A) max.
			L	Q			
SR10061R5ML□-□□□	1.5±20%	35	1k	7.960M	105.0	0.018	6.40
SR10062R2ML□-□□□	2.2±20%	35	1k	7.960M	68.0	0.021	5.40
SR10063R3ML□-□□□	3.3±20%	34	1k	7.960M	55.0	0.024	5.00
SR10063R9ML□-□□□	3.9±20%	34	1k	7.960M	48.0	0.027	4.60
SR10064R7ML□-□□□	4.7±20%	33	1k	7.960M	40.0	0.036	4.00
SR10065R6ML□-□□□	5.6±20%	33	1k	7.960M	35.0	0.040	3.80
SR10066R8ML□-□□□	6.8±20%	33	1k	7.960M	32.0	0.044	3.40
SR10068R2ML□-□□□	8.2±20%	31	1k	7.960M	24.0	0.048	3.00
SR1006100ML□-□□□	10.0±20%	30	1k	2.520M	21.0	0.060	2.60
SR1006120ML□-□□□	12.0±20%	30	1k	2.520M	20.0	0.070	2.45
SR1006150ML□-□□□	15.0±20%	30	1k	2.520M	16.0	0.080	2.25
SR1006180ML□-□□□	18.0±20%	30	1k	2.520M	15.0	0.090	2.15
SR1006220ML□-□□□	22.0±20%	25	1k	2.520M	13.0	0.100	1.95
SR1006270ML□-□□□	27.0±20%	25	1k	2.520M	11.0	0.110	1.75
SR1006330KL□-□□□	33.0±10%	25	1k	2.520M	10.0	0.120	1.50
SR1006390KL□-□□□	39.0±10%	20	1k	2.520M	9.0	0.140	1.35
SR1006470KL□-□□□	47.0±10%	20	1k	2.520M	8.0	0.170	1.25
SR1006560KL□-□□□	56.0±10%	20	1k	2.520M	7.5	0.190	1.15
SR1006680KL□-□□□	68.0±10%	15	1k	2.520M	7.0	0.220	1.10
SR1006820KL□-□□□	82.0±10%	15	1k	2.520M	6.0	0.250	1.00
SR1006101KL□-□□□	100.0±10%	15	1k	0.796M	5.2	0.350	0.97
SR1006121KL□-□□□	120.0±10%	15	1k	0.796M	5.0	0.400	0.89
SR1006151KL□-□□□	150.0±10%	15	1k	0.796M	4.5	0.470	0.78
SR1006181KL□-□□□	180.0±10%	12	1k	0.796M	4.0	0.630	0.72
SR1006221KL□-□□□	220.0±10%	12	1k	0.796M	3.8	0.730	0.66
SR1006271KL□-□□□	270.0±10%	12	1k	0.796M	3.5	0.970	0.57
SR1006331KL□-□□□	330.0±10%	12	1k	0.796M	3.2	1.150	0.52
SR1006391KL□-□□□	390.0±10%	12	1k	0.796M	3.0	1.300	0.48
SR1006471KL□-□□□	470.0±10%	12	1k	0.796M	2.5	1.480	0.42
SR1006561KL□-□□□	560.0±10%	12	1k	0.796M	2.3	1.900	0.33
SR1006681KL□-□□□	680.0±10%	12	1k	0.796M	2.1	2.250	0.28
SR1006821KL□-□□□	820.0±10%	10	1k	0.796M	2.0	2.550	0.24
SR1006102KL□-□□□	1000.0±10%	29	1k	0.252M	1.9	3.100	0.23
SR1006122KL□-□□□	1200.0±10%	32	1k	0.252M	1.8	4.200	0.21
SR1006152KL□-□□□	1500.0±10%	31	1k	0.252M	1.7	5.000	0.19
SR1006182KL□-□□□	1800.0±10%	31	1k	0.252M	1.6	6.800	0.17
SR1006222KL□-□□□	2200.0±10%	31	1k	0.252M	1.5	7.600	0.16
SR1006272KL□-□□□	2700.0±10%	32	1k	0.252M	1.4	11.600	0.14
SR1006332KL□-□□□	3300.0±10%	32	1k	0.252M	1.3	13.500	0.12
SR1006392KL□-□□□	3900.0±10%	31	1k	0.252M	1.2	14.800	0.11
SR1006472KL□-□□□	4700.0±10%	32	1k	0.252M	0.8	18.000	0.10

1). □: Packaging information : □ Code

2). "- □□□ " : Reference code

3). Electrical specifications at 25°C

4). IDC base on $\Delta L/L0A=10\%$ max.
& Temp. rise 40°C max.

AR-001C



SPECIFICATION FOR APPROVAL

REF. :

PROD. NAME	SMD Power Inductor	ABC'S DWG NO.	SR1006□□□□L□-□□□		
		REV.	20150507-I	PAGE	3

V . Curve :

SR10061R5ML□

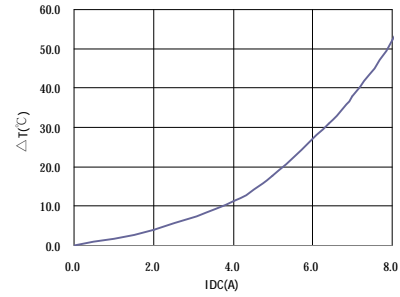
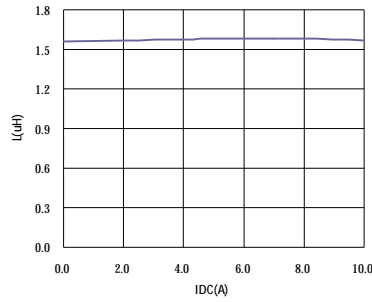

SR1006100ML□

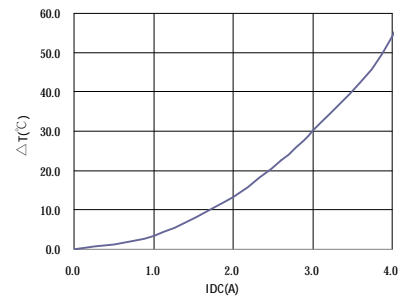
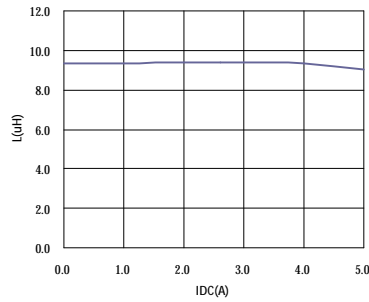

SR1006101KL□

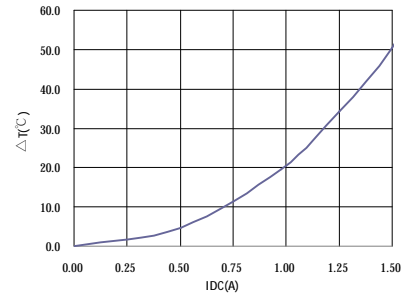
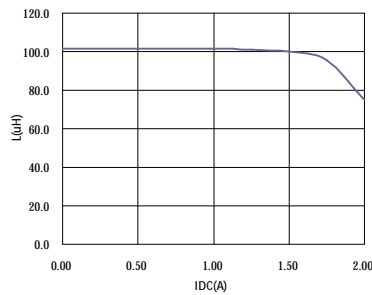

SR1006472KL□

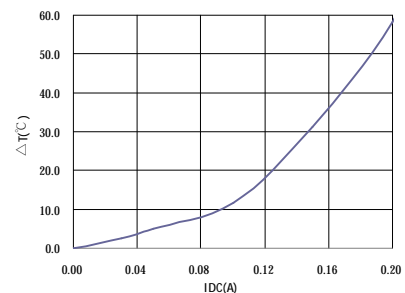
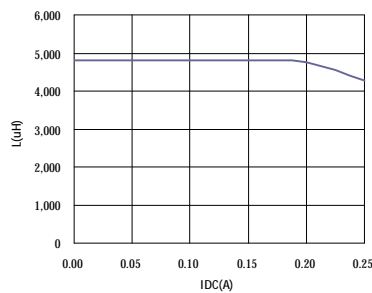

AR-001C

SPECIFICATION FOR APPROVAL

REF. :

PROD. NAME	SMD Power Inductor	ABC'S DWG NO.	SR1006□□□□L□-□□□		
		REV.	20150507-I	PAGE	4

VI . Packaging information :

(1) Configuration

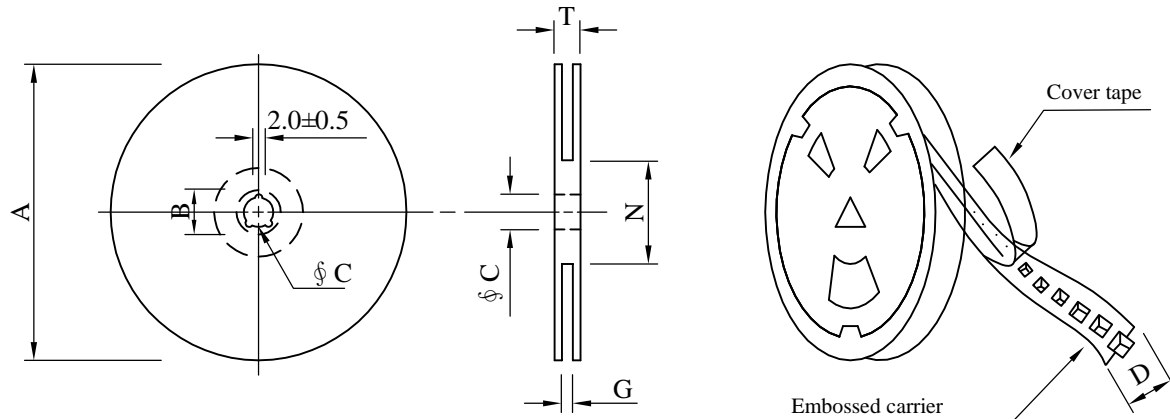

※Carrier tape width : D

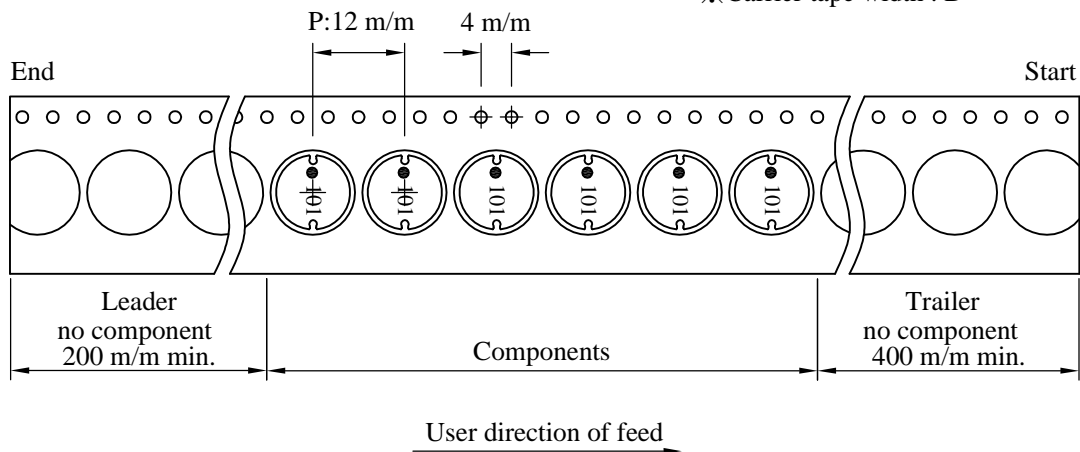

(2) Dimensions

Unit:m/m

Style	A	B	C	D	G	N	T
13 - 24	330	21±0.8	13±0.5	24	26 ⁺⁰	60 ⁻⁰	30.4

(3) Q'TY & G.W. Per package

Code	Inner : Reel			Outer : Carton		
	Q'TY (pcs)	G.W. (gw)	Style	Q'TY (pcs)	G.W. (Kg)	Size (cm)
B - D	800	1,550	13 - 24	3,200	7.5	38 x 37 x 22
E	500	1,140	13 - 24	2,000	5.8	38 x 37 x 22

AR-001C

SPECIFICATION FOR APPROVAL

REF. :

PROD. NAME	SMD Power Inductor	ABC'S DWG NO.	SR1006□□□□L□-□□□		
		REV.	20150507-I	PAGE	5

VII . Reliability test :

Item	Reference documents	Test Condition	Test Specification
1.High Temperature Exposure	MIL-STD-202 Method 108	1.Temperature: 125±2℃ 2.Time:96±2 hours.	1.No mechanical or electrical damage. 2.Inductance shall not change more than ±10%.
2.Temperature Cycling	JESD22-A 104	1.Temperature: -40℃ ~ +125℃ 2.Number of cycle:100 cycle 3.Dwell time:30 minutes	1.No mechanical or electrical damage. 2.Inductance shall not change more than ±10%.
3.Biased Humidity Test	MIL-STD-202 Method 103	1.Temperature : 85±2 ℃ 2.Humidity: 85% RH. 3.Time:96±2 Hours	1.No mechanical or electrical damage. 2.Inductance shall not change more than ±10%.
4.Operational Life	JESD22-A 108	1.Temperature: 125℃ (Temp. rise included) 2.Time:96±2 hours. 3.Rated current	1.No mechanical or electrical damage. 2.Inductance shall not change more than ±10%.
5.External Visual	JESD22-B 101 & MIL-STD-883 Method 2009	Inspect product constructions, marking and workmanship.	1.No pollution on the surface of products. 2.Clear marking. 3.No crack.
6.Physical Dimensions	JESD22-B 100	Verify physical dimensions to the applicable product detail specification.	Per product specification standard
7.Resistance to solvents	MIL-STD-202 Method 215	Immerse into solvent for 3±0.5 minutes & brush 10 times for 3 cycles.	1.No body change in apperance. 2.No marking blurred. 3.Inductance shall not change more than ±10%.
8.Vibration Test	MIL-STD-202 Method 204	1.Frequency and Amplitud : 10-2000-10 Hz, 1.5 mm. 2.Direction:X, Y, Z 3.Test duration:2 hours for each direction, 6 hours in total.	1.No mechanical or electrical damage. 2.Inductance shall not change more than ±10%.
9.Resistance To Soldering Heat Test	MIL-STD-202 Method 210 & J-STD020D.1	1.Highest temperature : 245±5℃. 2.Time (temp. ≥ 217℃) : 60~150 Second. 3.IR reflow times : 3 times.	1.No mechanical or electrical damage. 2.Inductance shall not change more than ±10%.
10.Saturation Current	JIS C 6436 & User SPEC.	1.Applied rated current for 5 second. 2.Saturation current	Inductance shall not drop more than 10% max.
11.Over load	JIS C 6436 & User SPEC.	1.Applied one and half rated current for a period of 5 minutes. 2.Rated current	No electrical or mechanical damage
12.Temperature Rise Current	JIS C 6436 & User SPEC.	1.Applied rated current for 10 minutes. 2.Temperature measure by digital surface thermometer. 3.Irms current	Surface temperature rise is less than 40℃ max.
13.Solderability Test	J-STD-002 & JESD22-B 102	1.Baking in pre-testing : 150±5℃ / 16Hours±30 min. 2.Peak temperature : 240±5℃ 3.Time (temp. ≥ 217℃) : 60~150 second. 4.IR reflow times : 1 times.	More than 95% soldering coverage min on terminations.
14.Electrical Characteriazation	MIL-STD-202 Method 304 & User SPEC.	1.Operating temperature : -40℃~125℃ 2.Room temperature : 25℃.	1.No mechanical or electrical damage. 2.Inductance shall not change more than ±10%.
15.Drop	CNS-C6354 & GB/T 2423.8	1.Products shall be mounted on SPEC. pcb and dropped down from a heigh of 1m 2.Drop total time : 6 time (Every side ofsample drop 2 time)	1. Adhesion on PCB shall be enough. 2. Product appearance shall not break. 3. No electrical damage.
16.Terminal Strength Test	IEC 60068-2-21	1.Apply push force to samples mounted on PCB. 2.Force of 1.8 kg for 60±1 seconds.	After test, inductors shall be no mechanical damage.

AR-001C